

Supplementary Table 1. Distribution of responses for each item on the initial pool.

No	Variable	Label	Stats / Values	Freqs (% of Valid)	Graph	Valid	Missing
1	I1 [haven_labelled, vctrs_vctr, double]	During the last therapy session, how much did I feel regret and/or sorry about something I said to them or did during the session, though I still think it was something correct.	Mean (sd) : 1.1 (0.4) min < med < max: 1 < 1 < 4 IQR (CV) : 0 (0.4)	1 : 492 (88.5%) 2 : 54 (9.7%) 3 : 6 (1.1%) 4 : 4 (0.7%)	IIIIIIIIIIIIIIIIIIII I	556 (100.0%)	0 (0.0%)
2	I2 [haven_labelled, vctrs_vctr, double]	During the last therapy session, how much did I feel happy to see them.	Mean (sd) : 3.4 (1.1) min < med < max: 1 < 3 < 5 IQR (CV) : 1 (0.3)	1 : 25 (4.5%) 2 : 97 (17.4%) 3 : 173 (31.1%) 4 : 176 (31.7%) 5 : 85 (15.3%)	III IIIIII IIIIII III	556 (100.0%)	0 (0.0%)
3	I3 [haven_labelled, vctrs_vctr, double]	During the last therapy session, how much did I speak too frequently and/or too long, much more than I usually do with my other patients.	Mean (sd) : 1.3 (0.6) min < med < max: 1 < 1 < 5 IQR (CV) : 1 (0.4)	1 : 415 (74.6%) 2 : 120 (21.6%) 3 : 17 (3.1%) 4 : 3 (0.5%) 5 : 1 (0.2%)	IIIIIIIIIIIIIIIIII IIII	556 (100.0%)	0 (0.0%)
4	I4 [haven_labelled, vctrs_vctr, double]	At a certain point in the last therapy session, how much did I feel like I could go crazy.	Mean (sd) : 1.1 (0.3) min < med < max: 1 < 1 < 4 IQR (CV) : 0 (0.3)	1 : 529 (95.1%) 2 : 21 (3.8%) 3 : 4 (0.7%) 4 : 2 (0.4%)	IIIIIIIIIIIIIIIIIIII	556 (100.0%)	0 (0.0%)
5	I5 [haven_labelled, vctrs_vctr, double]	During the last therapy session, how much did, I find it hard to be spontaneous.	Mean (sd) : 1.3 (0.6) min < med < max: 1 < 1 < 5 IQR (CV) : 0 (0.4)	1 : 437 (78.6%) 2 : 103 (18.5%) 3 : 10 (1.8%) 4 : 4 (0.7%) 5 : 2 (0.4%)	IIIIIIIIIIIIIIIIII III	556 (100.0%)	0 (0.0%)
6	I6 [haven_labelled, vctrs_vctr, double]	During the last therapy session, how much did I find myself haughty or arrogant with them.	Mean (sd) : 1.1 (0.3) min < med < max: 1 < 1 < 3 IQR (CV) : 0 (0.2)	1 : 525 (94.4%) 2 : 28 (5.0%) 3 : 3 (0.5%)	IIIIIIIIIIIIIIIIIIII I	556 (100.0%)	0 (0.0%)
7	I7 [haven_labelled, vctrs_vctr, double]	During the last therapy session, how much did I feel displeasure or anger because of something they said or did to me.	Mean (sd) : 1.1 (0.3) min < med < max: 1 < 1 < 4 IQR (CV) : 0 (0.3)	1 : 526 (94.6%) 2 : 27 (4.9%) 3 : 2 (0.4%) 4 : 1 (0.2%)	IIIIIIIIIIIIIIIIIIII	556 (100.0%)	0 (0.0%)
8	I8 [haven_labelled, vctrs_vctr, double]	During the last therapy session, how much did I feel hopeless for them.	Mean (sd) : 1.3 (0.6) min < med < max: 1 < 1 < 5 IQR (CV) : 0 (0.5)	1 : 429 (77.2%) 2 : 92 (16.5%) 3 : 27 (4.9%) 4 : 6 (1.1%) 5 : 2 (0.4%)	IIIIIIIIIIIIIIIIII III	556 (100.0%)	0 (0.0%)
9	I9 [haven_labelled, vctrs_vctr, double]	During the last therapy session, how much did I feel aloof, emotionally distant from them.	Mean (sd) : 1.2 (0.5) min < med < max: 1 < 1 < 5 IQR (CV) : 0 (0.4)	1 : 457 (82.2%) 2 : 86 (15.5%) 3 : 8 (1.4%) 4 : 3 (0.5%) 5 : 2 (0.4%)	IIIIIIIIIIIIIIIIII III	556 (100.0%)	0 (0.0%)
10	I10 [haven_labelled, vctrs_vctr, double]	During the last therapy session, how much did I feel romantically attracted to them, like they would be my spouse or lover.	Mean (sd) : 1 (0.3) min < med < max: 1 < 1 < 4 IQR (CV) : 0 (0.3)	1 : 538 (96.8%) 2 : 11 (2.0%) 3 : 6 (1.1%) 4 : 1 (0.2%)	IIIIIIIIIIIIIIIIIIII	556 (100.0%)	0 (0.0%)
11	I11	During the last therapy session, how	Mean (sd) : 1 (0.2)	1 : 543 (97.7%)	IIIIIIIIIIIIIIIIIIII	556	0

	[haven_labelled, vctrs_vctr, double]	much did I apologize to them for something I said or did during the session, but without having a good reason to apologize.	min < med < max: 1 < 1 < 4 IQR (CV) : 0 (0.2)	2 : 10 (1.8%) 3 : 2 (0.4%) 4 : 1 (0.2%)		(100.0%) (0.0%)
12	I12 [haven_labelled, vctrs_vctr, double]	During the last therapy session, how much did I find myself flirting with them.	Mean (sd) : 1 (0.2) min < med < max: 1 < 1 < 4 IQR (CV) : 0 (0.2)	1 : 542 (97.5%) 2 : 12 (2.2%) 3 : 1 (0.2%) 4 : 1 (0.2%)	IIIIIIIIIIIIIIIIIIII	556 (100.0%) 0 (0.0%)
13	I13 [haven_labelled, vctrs_vctr, double]	During the last therapy session, how much did I delay the session although there weren't any real barriers preventing to start on time.	Mean (sd) : 1 (0.3) min < med < max: 1 < 1 < 3 IQR (CV) : 0 (0.2)	1 : 534 (96.0%) 2 : 17 (3.1%) 3 : 5 (0.9%)	IIIIIIIIIIIIIIIIIIII	556 (100.0%) 0 (0.0%)
14	I14 [haven_labelled, vctrs_vctr, double]	During the last therapy session, how much did I feel compelled to act in a more directive way than usual, telling them explicitly what to do.	Mean (sd) : 1.5 (0.7) min < med < max: 1 < 1 < 5 IQR (CV) : 1 (0.5)	1 : 348 (62.6%) 2 : 159 (28.6%) 3 : 33 (5.9%) 4 : 15 (2.7%) 5 : 1 (0.2%)	IIIIIIIIII IIIII I	556 (100.0%) 0 (0.0%)
15	I15 [haven_labelled, vctrs_vctr, double]	During the last therapy session, how much did I feel frustrated in my efforts to help them.	Mean (sd) : 1.5 (0.8) min < med < max: 1 < 1 < 5 IQR (CV) : 1 (0.6)	1 : 353 (63.5%) 2 : 139 (25.0%) 3 : 40 (7.2%) 4 : 18 (3.2%) 5 : 6 (1.1%)	IIIIIIIIIIII IIIII I	556 (100.0%) 0 (0.0%)
16	I16 [haven_labelled, vctrs_vctr, double]	During the last therapy session, how much did I feel that my atypical (emotional, cognitive, or behavioral) reactions to them interfere with my therapeutic capacity.	Mean (sd) : 1.1 (0.4) min < med < max: 1 < 1 < 4 IQR (CV) : 0 (0.4)	1 : 486 (87.4%) 2 : 62 (11.2%) 3 : 6 (1.1%) 4 : 2 (0.4%)	IIIIIIIIIIIIIIIIIIII II	556 (100.0%) 0 (0.0%)
17	I17 [haven_labelled, vctrs_vctr, double]	During the last therapy session, how much did I feel like it wouldn't matter to them if I were replaced by any other therapist.	Mean (sd) : 1.4 (0.9) min < med < max: 1 < 1 < 5 IQR (CV) : 0 (0.6)	1 : 425 (76.4%) 2 : 75 (13.5%) 3 : 32 (5.8%) 4 : 14 (2.5%) 5 : 10 (1.8%)	IIIIIIIIIIIIIIIIIIII II I	556 (100.0%) 0 (0.0%)
18	I18 [haven_labelled, vctrs_vctr, double]	During the last therapy session, how much did I feel belittled, underestimated, or unappreciated and/or that my interventions were dismissed or overlooked by them.	Mean (sd) : 1.1 (0.5) min < med < max: 1 < 1 < 5 IQR (CV) : 0 (0.4)	1 : 494 (88.8%) 2 : 46 (8.3%) 3 : 12 (2.2%) 4 : 3 (0.5%) 5 : 1 (0.2%)	IIIIIIIIIIIIIIIIIIII I	556 (100.0%) 0 (0.0%)
19	I19 [haven_labelled, vctrs_vctr, double]	During the last therapy session, how much did I feel contempt toward them.	Mean (sd) : 1.1 (0.4) min < med < max: 1 < 1 < 5 IQR (CV) : 0 (0.4)	1 : 521 (93.7%) 2 : 23 (4.1%) 3 : 6 (1.1%) 4 : 5 (0.9%) 5 : 1 (0.2%)	IIIIIIIIIIIIIIIIIIII	556 (100.0%) 0 (0.0%)
20	I20 [haven_labelled, vctrs_vctr, double]	During the last therapy session, how much did I feel a sudden deep and pervading anguish during the session.	Mean (sd) : 1.2 (0.5) min < med < max: 1 < 1 < 4 IQR (CV) : 0 (0.4)	1 : 489 (87.9%) 2 : 49 (8.8%) 3 : 16 (2.9%) 4 : 2 (0.4%)	IIIIIIIIIIIIIIIIIIII I	556 (100.0%) 0 (0.0%)
21	I21 [haven_labelled, vctrs_vctr, double]	During the last therapy session, how much did I feel emotionally numb or even apathetic to them.	Mean (sd) : 1.1 (0.4) min < med < max: 1 < 1 < 5 IQR (CV) : 0 (0.4)	1 : 499 (89.7%) 2 : 50 (9.0%) 3 : 4 (0.7%) 4 : 1 (0.2%)	IIIIIIIIIIIIIIIIIIII I	556 (100.0%) 0 (0.0%)

					5 : 2 (0.4%)			
22	I22 [haven_labelled, vctrs_vctr, double]	During the last therapy session, how much did I feel flattered about something they said about our work or me.	Mean (sd) : 1.7 (0.9) min < med < max: 1 < 1 < 5 IQR (CV) : 1 (0.5)	1 : 308 (55.4%) 2 : 164 (29.5%) 3 : 61 (11.0%) 4 : 14 (2.5%) 5 : 9 (1.6%)	IIIIIIIIII IIII II	556 (100.0%)	0 (0.0%)	
23	I23 [haven_labelled, vctrs_vctr, double]	During the last therapy session, how much did I over-support them in a way that doesn't help or may even block them from working through their problem.	Mean (sd) : 1.2 (0.5) min < med < max: 1 < 1 < 4 IQR (CV) : 0 (0.4)	1 : 439 (79.0%) 2 : 103 (18.5%) 3 : 13 (2.3%) 4 : 1 (0.2%)	IIIIIIIIIIIIIIIIII III	556 (100.0%)	0 (0.0%)	
24	I24 [haven_labelled, vctrs_vctr, double]	Before or during the last therapy session, how much did I hope they would not show up for the session (this for reasons other than my possible general tiredness or overloaded personal/professional commitments).	Mean (sd) : 1.1 (0.4) min < med < max: 1 < 1 < 5 IQR (CV) : 0 (0.4)	1 : 503 (90.5%) 2 : 43 (7.7%) 3 : 7 (1.3%) 4 : 2 (0.4%) 5 : 1 (0.2%)	IIIIIIIIIIIIIIIIII I	556 (100.0%)	0 (0.0%)	
25	I25 [haven_labelled, vctrs_vctr, double]	During the last therapy session, how much did I feel like they are not worth my time and effort.	Mean (sd) : 1.1 (0.5) min < med < max: 1 < 1 < 5 IQR (CV) : 0 (0.4)	1 : 523 (94.1%) 2 : 21 (3.8%) 3 : 4 (0.7%) 4 : 6 (1.1%) 5 : 2 (0.4%)	IIIIIIIIIIIIIIIIII IIIIIIIIIIIIIIIIII	556 (100.0%)	0 (0.0%)	
26	I26 [haven_labelled, vctrs_vctr, double]	During the last therapy session, how much did I find it difficult or even got lost trying to follow their sequence of thoughts.	Mean (sd) : 1.3 (0.6) min < med < max: 1 < 1 < 5 IQR (CV) : 1 (0.5)	1 : 406 (73.0%) 2 : 121 (21.8%) 3 : 24 (4.3%) 4 : 4 (0.7%) 5 : 1 (0.2%)	IIIIIIIIIIIIIIIIII IIII	556 (100.0%)	0 (0.0%)	
27	I27 [haven_labelled, vctrs_vctr, double]	During the last therapy session, how much did I do all I could for them to a greater extent than for my other patients.	Mean (sd) : 1.2 (0.6) min < med < max: 1 < 1 < 4 IQR (CV) : 0 (0.5)	1 : 462 (83.1%) 2 : 63 (11.3%) 3 : 18 (3.2%) 4 : 13 (2.3%)	IIIIIIIIIIIIIIIIII II	556 (100.0%)	0 (0.0%)	
28	I28 [haven_labelled, vctrs_vctr, double]	During the last therapy session, how much did I complain to them about something of my own or, however, not relevant to therapy.	Min : 1 Mean : 1.1 Max : 2	1 : 528 (95.0%) 2 : 28 (5.0%)	IIIIIIIIIIIIIIIIII I	556 (100.0%)	0 (0.0%)	
29	I29 [haven_labelled, vctrs_vctr, double]	During the last therapy session, how much did I feel mad at them.	Mean (sd) : 1.1 (0.4) min < med < max: 1 < 1 < 4 IQR (CV) : 0 (0.4)	1 : 504 (90.6%) 2 : 40 (7.2%) 3 : 11 (2.0%) 4 : 1 (0.2%)	IIIIIIIIIIIIIIIIII I	556 (100.0%)	0 (0.0%)	
30	I30 [haven_labelled, vctrs_vctr, double]	During the last therapy session, how was I distracted and absent from what is happening in session more easily/ often/ longer than I usually do with other patients.	Mean (sd) : 1.2 (0.5) min < med < max: 1 < 1 < 5 IQR (CV) : 0 (0.4)	1 : 448 (80.6%) 2 : 93 (16.7%) 3 : 13 (2.3%) 4 : 1 (0.2%) 5 : 1 (0.2%)	IIIIIIIIIIIIIIIIII III	556 (100.0%)	0 (0.0%)	
31	I31 [haven_labelled, vctrs_vctr, double]	During the last therapy session, how much did I break the therapeutic boundaries by acting more like a friend than their therapist.	Mean (sd) : 1.2 (0.4) min < med < max: 1 < 1 < 3 IQR (CV) : 0 (0.3)	1 : 468 (84.2%) 2 : 86 (15.5%) 3 : 2 (0.4%)	IIIIIIIIIIIIIIIIII III	556 (100.0%)	0 (0.0%)	
32	I32	During the last therapy session, how	Mean (sd) : 1.4 (0.6)	1 : 348 (62.6%)	IIIIIIIIIIIIIIIIII	556	0	

	[haven_labelled, vctrs_vctr, double]	much did I give them too much advice or give it too quickly or directly, foreclosing the reflection on / exploration of problems and solutions.	min < med < max: 1 < 1 < 4 IQR (CV) : 1 (0.4)	2 : 176 (31.7%) 3 : 28 (5.0%) 4 : 4 (0.7%)	IIIIII I	(100.0%) (0.0%)
33	I33 [haven_labelled, vctrs_vctr, double]	During the last therapy session, how much did I feel responsible for their ongoing emotional suffering, although I know I have done everything possible so far.	Mean (sd) : 1.3 (0.6) min < med < max: 1 < 1 < 5 IQR (CV) : 0 (0.5)	1 : 440 (79.1%) 2 : 88 (15.8%) 3 : 24 (4.3%) 4 : 3 (0.5%) 5 : 1 (0.2%)	IIIIIIIIIIIIIIIIIIII III	556 0 (100.0%) (0.0%)
34	I34 [haven_labelled, vctrs_vctr, double]	During the last therapy session, how much did I feel distressed and/or excited by their sexual feelings/advances toward me.	Mean (sd) : 1 (0.3) min < med < max: 1 < 1 < 5 IQR (CV) : 0 (0.3)	1 : 536 (96.4%) 2 : 17 (3.1%) 3 : 1 (0.2%) 4 : 1 (0.2%) 5 : 1 (0.2%)	IIIIIIIIIIIIIIIIIIII	556 0 (100.0%) (0.0%)
35	I35 [haven_labelled, vctrs_vctr, double]	During the last therapy session, how much did I feel appreciated by them.	Mean (sd) : 3.5 (1) min < med < max: 1 < 4 < 5 IQR (CV) : 1 (0.3)	1 : 13 (2.3%) 2 : 78 (14.0%) 3 : 179 (32.2%) 4 : 194 (34.9%) 5 : 92 (16.5%)	II IIIIII IIIIII III	556 0 (100.0%) (0.0%)
36	I36 [haven_labelled, vctrs_vctr, double]	During the last therapy session, how much did I feel jealous of them.	Mean (sd) : 1.1 (0.3) min < med < max: 1 < 1 < 3 IQR (CV) : 0 (0.3)	1 : 507 (91.2%) 2 : 43 (7.7%) 3 : 6 (1.1%)	IIIIIIIIIIIIIIIIIIII I	556 0 (100.0%) (0.0%)
37	I37 [haven_labelled, vctrs_vctr, double]	During the last therapy session, how much did I think what we are working on was interesting.	Mean (sd) : 3.7 (1) min < med < max: 1 < 4 < 5 IQR (CV) : 1 (0.3)	1 : 23 (4.1%) 2 : 37 (6.7%) 3 : 142 (25.5%) 4 : 228 (41.0%) 5 : 126 (22.7%)	I IIIIII IIIIIIII IIII	556 0 (100.0%) (0.0%)
38	I38 [haven_labelled, vctrs_vctr, double]	During the last therapy session, how much did I feel annoyed, irritated, or angry with them.	Mean (sd) : 1.3 (0.6) min < med < max: 1 < 1 < 5 IQR (CV) : 0 (0.5)	1 : 447 (80.4%) 2 : 81 (14.6%) 3 : 18 (3.2%) 4 : 9 (1.6%) 5 : 1 (0.2%)	IIIIIIIIIIIIIIIIIIII II	556 0 (100.0%) (0.0%)
39	I39 [haven_labelled, vctrs_vctr, double]	During the last therapy session, how much did, I feel overall comfortable and enjoy working with them.	Mean (sd) : 4 (1.1) min < med < max: 1 < 4 < 5 IQR (CV) : 1 (0.3)	1 : 29 (5.2%) 2 : 29 (5.2%) 3 : 75 (13.5%) 4 : 223 (40.1%) 5 : 200 (36.0%)	I I II IIIIIIII IIIIIIII	556 0 (100.0%) (0.0%)
40	I40 [haven_labelled, vctrs_vctr, double]	During the last therapy session, how much did I feel criticized by them.	Mean (sd) : 1.1 (0.4) min < med < max: 1 < 1 < 4 IQR (CV) : 0 (0.4)	1 : 492 (88.5%) 2 : 49 (8.8%) 3 : 12 (2.2%) 4 : 3 (0.5%)	IIIIIIIIIIIIIIIIIIII I	556 0 (100.0%) (0.0%)
41	I41 [haven_labelled, vctrs_vctr, double]	During the last therapy session, how much did I feel enthusiastic about working together with them.	Mean (sd) : 3.5 (1.1) min < med < max: 1 < 4 < 5 IQR (CV) : 1 (0.3)	1 : 25 (4.5%) 2 : 69 (12.4%) 3 : 148 (26.6%) 4 : 211 (37.9%) 5 : 103 (18.5%)	II IIIIII IIIIIIII III	556 0 (100.0%) (0.0%)
42	I42 [haven_labelled, vctrs_vctr, double]	During the last therapy session, I found it hard to give interpretations, comments, or suggestions about certain specific, difficult topics (e.g.,	Mean (sd) : 1.2 (0.6) min < med < max: 1 < 1 < 5 IQR (CV) : 0 (0.5)	1 : 458 (82.4%) 2 : 75 (13.5%) 3 : 17 (3.1%) 4 : 4 (0.7%)	IIIIIIIIIIIIIIIIIIII II	556 0 (100.0%) (0.0%)

		sexuality, anger, envy, etc.).		5 : 2 (0.4%)			
43	I43 [haven_labelled, vctrs_vctr, double]	During the last therapy session, how much did I feel fearful of them, like I'm threatened, in danger, and very tense.	Mean (sd) : 1 (0.2) min < med < max: 1 < 1 < 3 IQR (CV) : 0 (0.2)	1 : 542 (97.5%) 2 : 11 (2.0%) 3 : 3 (0.5%)	IIIIIIIIIIIIIIIIIIII	556 (100.0%)	0 (0.0%)
44	I44 [haven_labelled, vctrs_vctr, double]	During the last therapy session, I got easily bored with them.	Mean (sd) : 1.3 (0.6) min < med < max: 1 < 1 < 5 IQR (CV) : 0 (0.5)	1 : 429 (77.2%) 2 : 101 (18.2%) 3 : 15 (2.7%) 4 : 9 (1.6%) 5 : 2 (0.4%)	IIIIIIIIIIIIIIIIII III	556 (100.0%)	0 (0.0%)
45	I45 [haven_labelled, vctrs_vctr, double]	During the last therapy session, how much did I feel drowsy despite the absence of objective physical tiredness or exhaustion.	Mean (sd) : 1.2 (0.5) min < med < max: 1 < 1 < 5 IQR (CV) : 0 (0.4)	1 : 470 (84.5%) 2 : 69 (12.4%) 3 : 13 (2.3%) 4 : 3 (0.5%) 5 : 1 (0.2%)	IIIIIIIIIIIIIIIIII II	556 (100.0%)	0 (0.0%)
46	I46 [haven_labelled, vctrs_vctr, double]	During the last therapy session, how much did I feel sexually aroused or attracted to them.	Mean (sd) : 1.1 (0.4) min < med < max: 1 < 1 < 5 IQR (CV) : 0 (0.4)	1 : 518 (93.2%) 2 : 29 (5.2%) 3 : 5 (0.9%) 4 : 3 (0.5%) 5 : 1 (0.2%)	IIIIIIIIIIIIIIIIII I	556 (100.0%)	0 (0.0%)
47	I47 [haven_labelled, vctrs_vctr, double]	During the last therapy session, how much did I feel confused, unable to grasp what was going on in them and/or in the relationship with me.	Mean (sd) : 1.3 (0.6) min < med < max: 1 < 1 < 4 IQR (CV) : 0 (0.4)	1 : 429 (77.2%) 2 : 101 (18.2%) 3 : 21 (3.8%) 4 : 5 (0.9%)	IIIIIIIIIIIIIIIIII III	556 (100.0%)	0 (0.0%)
48	I48 [haven_labelled, vctrs_vctr, double]	During the last therapy session, how much did I want to end the session early.	Mean (sd) : 1.2 (0.6) min < med < max: 1 < 1 < 5 IQR (CV) : 0 (0.5)	1 : 458 (82.4%) 2 : 80 (14.4%) 3 : 11 (2.0%) 4 : 4 (0.7%) 5 : 3 (0.5%)	IIIIIIIIIIIIIIIIII II	556 (100.0%)	0 (0.0%)
49	I49 [haven_labelled, vctrs_vctr, double]	During the last therapy session, I ended the session late, knowingly or not, but contrary to my habits.	Mean (sd) : 1.3 (0.7) min < med < max: 1 < 1 < 5 IQR (CV) : 0 (0.5)	1 : 450 (80.9%) 2 : 70 (12.6%) 3 : 29 (5.2%) 4 : 3 (0.5%) 5 : 4 (0.7%)	IIIIIIIIIIIIIIIIII II I	556 (100.0%)	0 (0.0%)
50	I50 [haven_labelled, vctrs_vctr, double]	During the last therapy session, how much did I feel they are one of my favorite patients.	Mean (sd) : 2.2 (1.1) min < med < max: 1 < 2 < 5 IQR (CV) : 2 (0.5)	1 : 201 (36.2%) 2 : 166 (29.9%) 3 : 106 (19.1%) 4 : 62 (11.2%) 5 : 21 (3.8%)	IIIIIII IIIIII IIII III II	556 (100.0%)	0 (0.0%)
51	I51 [haven_labelled, vctrs_vctr, double]	During the last therapy session, at times I felt bashful, embarrassed, or shy with them.	Mean (sd) : 1.1 (0.3) min < med < max: 1 < 1 < 3 IQR (CV) : 0 (0.3)	1 : 517 (93.0%) 2 : 37 (6.7%) 3 : 2 (0.4%)	IIIIIIIIIIIIIIIIII I	556 (100.0%)	0 (0.0%)
52	I52 [haven_labelled, vctrs_vctr, double]	During the last therapy session, how much did I feel envious of them in a way that causes me to dislike them and/or to wish they would lose what I envy about them.	Mean (sd) : 1 (0.2) min < med < max: 1 < 1 < 3 IQR (CV) : 0 (0.2)	1 : 545 (98.0%) 2 : 10 (1.8%) 3 : 1 (0.2%)	IIIIIIIIIIIIIIIIII IIIIIIIIIIIIIIIIII	556 (100.0%)	0 (0.0%)
53	I53 [haven_labelled, vctrs_vctr, double]	During the last therapy session, how much did	Mean (sd) : 1 (0.2) min < med < max:	1 : 541 (97.3%) 2 : 14 (2.5%)	IIIIIIIIIIIIIIIIII	556 (100.0%)	0 (0.0%)

		I feel like I was being cruel, sadistic, or abusive with them.	1 < 1 < 3 IQR (CV) : 0 (0.2)	3 : 1 (0.2%)			
54	I54 [haven_labelled, vctrs_vctr, double]	During the last therapy session, how much did I lose my composure, temper, or patience with this patient more easily than with other of my patients.	Mean (sd) : 1 (0.2) min < med < max: 1 < 1 < 3 IQR (CV) : 0 (0.2)	1 : 536 (96.4%) 2 : 17 (3.1%) 3 : 3 (0.5%)	IIIIIIIIIIIIIIIIIIII	556 (100.0%)	0 (0.0%)
55	I55 [haven_labelled, vctrs_vctr, double]	During the last therapy session, how much did I feel pity and compassion for them.	Mean (sd) : 2.4 (1.1) min < med < max: 1 < 2 < 5 IQR (CV) : 2 (0.5)	1 : 146 (26.3%) 2 : 160 (28.8%) 3 : 147 (26.4%) 4 : 89 (16.0%) 5 : 14 (2.5%)	IIIII IIIII IIIII III	556 (100.0%)	0 (0.0%)
56	I56 [haven_labelled, vctrs_vctr, double]	During the last therapy session, how much did I feel on guard with them over most or all the session length.	Mean (sd) : 1.2 (0.5) min < med < max: 1 < 1 < 4 IQR (CV) : 0 (0.4)	1 : 477 (85.8%) 2 : 69 (12.4%) 3 : 5 (0.9%) 4 : 5 (0.9%)	IIIIIIIIIIIIIIIIIIII II	556 (100.0%)	0 (0.0%)
57	I57 [haven_labelled, vctrs_vctr, double]	During the last therapy session, how much did I take a submissive role, leaving them the control of the session.	Mean (sd) : 1.5 (0.8) min < med < max: 1 < 1 < 5 IQR (CV) : 1 (0.5)	1 : 378 (68.0%) 2 : 116 (20.9%) 3 : 50 (9.0%) 4 : 11 (2.0%) 5 : 1 (0.2%)	IIIIIIIIIIIIIIIIIIII IIIII I	556 (100.0%)	0 (0.0%)
58	I58 [haven_labelled, vctrs_vctr, double]	During the last therapy session, how much did I have strong and intense feelings when in session with them, greater than those usually evoked in me by other patients.	Mean (sd) : 1.3 (0.6) min < med < max: 1 < 1 < 5 IQR (CV) : 0 (0.5)	1 : 444 (79.9%) 2 : 82 (14.7%) 3 : 20 (3.6%) 4 : 8 (1.4%) 5 : 2 (0.4%)	IIIIIIIIIIIIIIIIIIII II	556 (100.0%)	0 (0.0%)
59	I59 [haven_labelled, vctrs_vctr, double]	During the last therapy session, how much did I feel sickened by them.	Mean (sd) : 1 (0.3) min < med < max: 1 < 1 < 3 IQR (CV) : 0 (0.2)	1 : 535 (96.2%) 2 : 16 (2.9%) 3 : 5 (0.9%)	IIIIIIIIIIIIIIIIIIII	556 (100.0%)	0 (0.0%)
60	I60 [haven_labelled, vctrs_vctr, double]	During the last therapy session, how much did I regret taking them on as a patient.	Mean (sd) : 1.1 (0.4) min < med < max: 1 < 1 < 5 IQR (CV) : 0 (0.4)	1 : 505 (90.8%) 2 : 42 (7.6%) 3 : 4 (0.7%) 4 : 4 (0.7%) 5 : 1 (0.2%)	IIIIIIIIIIIIIIIIIIII I	556 (100.0%)	0 (0.0%)
61	I61 [haven_labelled, vctrs_vctr, double]	During the last therapy session, how much did I feel overall uncomfortable in the therapy hour with them.	Mean (sd) : 1.2 (0.6) min < med < max: 1 < 1 < 5 IQR (CV) : 0 (0.5)	1 : 473 (85.1%) 2 : 58 (10.4%) 3 : 11 (2.0%) 4 : 10 (1.8%) 5 : 4 (0.7%)	IIIIIIIIIIIIIIIIIIII II	556 (100.0%)	0 (0.0%)
62	I62 [haven_labelled, vctrs_vctr, double]	During the last therapy session, how much did I feel lied to and not trust what they told me.	Mean (sd) : 1.1 (0.4) min < med < max: 1 < 1 < 4 IQR (CV) : 0 (0.4)	1 : 504 (90.6%) 2 : 39 (7.0%) 3 : 10 (1.8%) 4 : 3 (0.5%)	IIIIIIIIIIIIIIIIIIII I	556 (100.0%)	0 (0.0%)
63	I63 [haven_labelled, vctrs_vctr, double]	During the last therapy session, how much did I collude with them, letting them engage in unhelpful or even detrimental thoughts, arguments, or patterns of behavior without addressing them.	Mean (sd) : 1.2 (0.5) min < med < max: 1 < 1 < 5 IQR (CV) : 0 (0.4)	1 : 463 (83.3%) 2 : 77 (13.8%) 3 : 14 (2.5%) 4 : 1 (0.2%) 5 : 1 (0.2%)	IIIIIIIIIIIIIIIIIIII II	556 (100.0%)	0 (0.0%)
64	I64	During the last therapy session, how	Mean (sd) : 1.2 (0.5)	1 : 462 (83.1%)	IIIIIIIIIIIIIIIIIIII	556	0

	[haven_labelled, vctrs_vctr, double]	much did I feel more sad or even depressed with them after the session.	min < med < max: 1 < 1 < 5 IQR (CV) : 0 (0.4)	2 : 74 (13.3%) 3 : 14 (2.5%) 4 : 5 (0.9%) 5 : 1 (0.2%)	II	(100.0%)	(0.0%)
65	I65 [haven_labelled, vctrs_vctr, double]	During the last therapy session, how much did I feel like they kept me in check.	Mean (sd) : 1.3 (0.6) min < med < max: 1 < 1 < 4 IQR (CV) : 0 (0.5)	1 : 443 (79.7%) 2 : 74 (13.3%) 3 : 30 (5.4%) 4 : 9 (1.6%)	IIIIIIIIIIIIIIIIIIII II I	556 (100.0%)	0 (0.0%)
66	I66 [haven_labelled, vctrs_vctr, double]	During the last therapy session, how much did I feel tenderness towards them, more than I usually feel for my other patients.	Mean (sd) : 1.7 (0.9) min < med < max: 1 < 1 < 5 IQR (CV) : 1 (0.5)	1 : 287 (51.6%) 2 : 172 (30.9%) 3 : 68 (12.2%) 4 : 20 (3.6%) 5 : 9 (1.6%)	IIIIIIIIII IIIIII II	556 (100.0%)	0 (0.0%)
67	I67 [haven_labelled, vctrs_vctr, double]	During the last therapy session, how much did I feel more protective of them than of most patients in my care.	Mean (sd) : 1.5 (0.8) min < med < max: 1 < 1 < 5 IQR (CV) : 1 (0.5)	1 : 352 (63.3%) 2 : 138 (24.8%) 3 : 47 (8.5%) 4 : 15 (2.7%) 5 : 4 (0.7%)	IIIIIIIIIIIIIIIIIIII IIII I	556 (100.0%)	0 (0.0%)
68	I68 [haven_labelled, vctrs_vctr, double]	During the last therapy session, how much did I feel good with the way the session went.	Mean (sd) : 3.9 (0.9) min < med < max: 1 < 4 < 5 IQR (CV) : 2 (0.2)	1 : 7 (1.3%) 2 : 30 (5.4%) 3 : 142 (25.5%) 4 : 233 (41.9%) 5 : 144 (25.9%)	I IIIIII IIIIIIIIII IIIIII	556 (100.0%)	0 (0.0%)
69	I69 [haven_labelled, vctrs_vctr, double]	During the last therapy session, how much did I feel drained and exhausted more than with my other patients.	Mean (sd) : 1.3 (0.6) min < med < max: 1 < 1 < 5 IQR (CV) : 0 (0.5)	1 : 441 (79.3%) 2 : 84 (15.1%) 3 : 22 (4.0%) 4 : 8 (1.4%) 5 : 1 (0.2%)	IIIIIIIIIIIIIIIIIIII III	556 (100.0%)	0 (0.0%)
70	I70 [haven_labelled, vctrs_vctr, double]	During the last therapy session, how much did I think I am not paid enough to deal with this patient.	Mean (sd) : 1.3 (0.8) min < med < max: 1 < 1 < 5 IQR (CV) : 0 (0.6)	1 : 459 (82.6%) 2 : 48 (8.6%) 3 : 35 (6.3%) 4 : 6 (1.1%) 5 : 8 (1.4%)	IIIIIIIIIIIIIIIIIIII I I	556 (100.0%)	0 (0.0%)
71	I71 [haven_labelled, vctrs_vctr, double]	During the last therapy session, how much did I find myself being condescending towards them.	Mean (sd) : 1.1 (0.3) min < med < max: 1 < 1 < 3 IQR (CV) : 0 (0.3)	1 : 511 (91.9%) 2 : 40 (7.2%) 3 : 5 (0.9%)	IIIIIIIIIIIIIIIIIIII I	556 (100.0%)	0 (0.0%)
72	I72 [haven_labelled, vctrs_vctr, double]	During the last therapy session, how much did I give them explicit verbal reassurance about my fondness for them, despite the fact that I usually don't do that for other patients.	Mean (sd) : 1.1 (0.4) min < med < max: 1 < 1 < 4 IQR (CV) : 0 (0.3)	1 : 503 (90.5%) 2 : 46 (8.3%) 3 : 5 (0.9%) 4 : 2 (0.4%)	IIIIIIIIIIIIIIIIIIII I	556 (100.0%)	0 (0.0%)
73	I73 [haven_labelled, vctrs_vctr, double]	During the last therapy session, how much did I have change the subject before a resolution, and without a clear therapeutic reason.	Mean (sd) : 1.2 (0.4) min < med < max: 1 < 1 < 4 IQR (CV) : 0 (0.4)	1 : 471 (84.7%) 2 : 75 (13.5%) 3 : 8 (1.4%) 4 : 2 (0.4%)	IIIIIIIIIIIIIIIIIIII II	556 (100.0%)	0 (0.0%)
74	I74 [haven_labelled, vctrs_vctr, double]	During the last therapy session, how much did I feel like I was incompetent or "not good enough" to help them.	Mean (sd) : 1.3 (0.6) min < med < max: 1 < 1 < 5 IQR (CV) : 0 (0.5)	1 : 421 (75.7%) 2 : 101 (18.2%) 3 : 28 (5.0%) 4 : 5 (0.9%) 5 : 1 (0.2%)	IIIIIIIIIIIIIIIIIIII III I	556 (100.0%)	0 (0.0%)

86	I86 [haven_labelled, vctrs_vctr, double]	During the last therapy session, how much did I feel like I needed their approval to say or do something during the session.	Mean (sd) : 1.2 (0.5) min < med < max: 1 < 1 < 4 IQR (CV) : 0 (0.4)	1 : 474 (85.3%) 2 : 66 (11.9%) 3 : 14 (2.5%) 4 : 2 (0.4%)	IIIIIIIIIIIIIIIIIIII II	556 (100.0%)	0 (0.0%)
87	I87 [haven_labelled, vctrs_vctr, double]	During the last therapy session, how much did I feel detached from the subject matter and not adequately involved in the conversation with them.	Mean (sd) : 1.2 (0.5) min < med < max: 1 < 1 < 4 IQR (CV) : 0 (0.4)	1 : 465 (83.6%) 2 : 75 (13.5%) 3 : 11 (2.0%) 4 : 5 (0.9%)	IIIIIIIIIIIIIIIIIIII II	556 (100.0%)	0 (0.0%)
88	I88 [haven_labelled, vctrs_vctr, double]	During the last therapy session, how much did I want to fire them from therapy.	Mean (sd) : 1.1 (0.4) min < med < max: 1 < 1 < 5 IQR (CV) : 0 (0.4)	1 : 514 (92.4%) 2 : 29 (5.2%) 3 : 8 (1.4%) 4 : 4 (0.7%) 5 : 1 (0.2%)	IIIIIIIIIIIIIIIIIIII I	556 (100.0%)	0 (0.0%)
89	I89 [haven_labelled, vctrs_vctr, double]	During the last therapy session, how much did I feel important to them.	Mean (sd) : 3.2 (1.1) min < med < max: 1 < 3 < 5 IQR (CV) : 2 (0.3)	1 : 39 (7.0%) 2 : 107 (19.2%) 3 : 191 (34.4%) 4 : 164 (29.5%) 5 : 55 (9.9%)	I III IIIIII IIIII I	556 (100.0%)	0 (0.0%)
90	I90 [haven_labelled, vctrs_vctr, double]	During the last therapy session, how much did I agree too often with them.	Mean (sd) : 1.3 (0.6) min < med < max: 1 < 1 < 4 IQR (CV) : 0 (0.4)	1 : 431 (77.5%) 2 : 98 (17.6%) 3 : 23 (4.1%) 4 : 4 (0.7%)	IIIIIIIIIIIIIIIIIIII III	556 (100.0%)	0 (0.0%)
91	I91 [haven_labelled, vctrs_vctr, double]	During the last therapy session, how much did I not validate them although they should be validated.	Mean (sd) : 1.1 (0.5) min < med < max: 1 < 1 < 4 IQR (CV) : 0 (0.4)	1 : 495 (89.0%) 2 : 47 (8.5%) 3 : 9 (1.6%) 4 : 5 (0.9%)	IIIIIIIIIIIIIIIIIIII I	556 (100.0%)	0 (0.0%)
92	I92 [haven_labelled, vctrs_vctr, double]	During the last therapy session, how much did I feel suspicious or mistrustful of their motivations or goals.	Mean (sd) : 1.2 (0.5) min < med < max: 1 < 1 < 5 IQR (CV) : 0 (0.4)	1 : 491 (88.3%) 2 : 50 (9.0%) 3 : 11 (2.0%) 4 : 2 (0.4%) 5 : 2 (0.4%)	IIIIIIIIIIIIIIIIIIII I	556 (100.0%)	0 (0.0%)
93	I93 [haven_labelled, vctrs_vctr, double]	During the last therapy session, how much did I find myself thinking that I would like to have them as a friend.	Mean (sd) : 1.4 (0.7) min < med < max: 1 < 1 < 5 IQR (CV) : 0 (0.5)	1 : 418 (75.2%) 2 : 94 (16.9%) 3 : 33 (5.9%) 4 : 9 (1.6%) 5 : 2 (0.4%)	IIIIIIIIIIIIIIIIIIII III I	556 (100.0%)	0 (0.0%)
94	I94 [haven_labelled, vctrs_vctr, double]	During the last therapy session, how much did I get overwhelmed by anxiety due to their emotional or care needs/requirements.	Mean (sd) : 1.2 (0.5) min < med < max: 1 < 1 < 4 IQR (CV) : 0 (0.4)	1 : 470 (84.5%) 2 : 69 (12.4%) 3 : 15 (2.7%) 4 : 2 (0.4%)	IIIIIIIIIIIIIIIIIIII II	556 (100.0%)	0 (0.0%)
95	I95 [haven_labelled, vctrs_vctr, double]	During the last therapy session, how much did I feel pushed or forced to set limits with them much firmer than with my other patients.	Mean (sd) : 1.2 (0.6) min < med < max: 1 < 1 < 5 IQR (CV) : 0 (0.5)	1 : 493 (88.7%) 2 : 41 (7.4%) 3 : 13 (2.3%) 4 : 6 (1.1%) 5 : 3 (0.5%)	IIIIIIIIIIIIIIIIIIII I	556 (100.0%)	0 (0.0%)
96	I96 [haven_labelled, vctrs_vctr, double]	During the last therapy session, how much did I fear that they wanted to quit psychotherapy, though they haven't said anything about that.	Mean (sd) : 1.2 (0.5) min < med < max: 1 < 1 < 5 IQR (CV) : 0 (0.4)	1 : 488 (87.8%) 2 : 48 (8.6%) 3 : 15 (2.7%) 4 : 3 (0.5%) 5 : 2 (0.4%)	IIIIIIIIIIIIIIIIIIII I	556 (100.0%)	0 (0.0%)
97	I97	During the last therapy session, how	Mean (sd) : 1.6 (0.9)	1 : 343 (61.7%)	IIIIIIIIIIIIIIIIIIII	556	0

	[haven_labelled, vctrs_vctr, double]	much was I more concerned with their feelings, needs, and wishes than with other patients.	min < med < max: 1 < 1 < 5 IQR (CV) : 0 (0.5)	2 : 89 (16.0%) 3 : 33 (5.9%) 4 : 8 (1.4%) 5 : 3 (0.5%)	III I	(100.0%) (0.0%)
109	I109 [haven_labelled, vctrs_vctr, double]	During the last therapy session, how much was I quieter than usual or say mostly superficial things because I was afraid that a wrong word could cause them an outburst of rage or a breakdown, or make them walk out of session.	Mean (sd) : 1.1 (0.3) min < med < max: 1 < 1 < 4 IQR (CV) : 0 (0.3)	1 : 534 (96.0%) 2 : 16 (2.9%) 3 : 5 (0.9%) 4 : 1 (0.2%)	IIIIIIIIIIIIIIIIIIII I	556 (100.0%) (0.0%)
110	I110 [haven_labelled, vctrs_vctr, double]	During the last therapy session, how much did I find it hard to keep a firm sense of who I am as a therapist and person over the therapy hour.	Mean (sd) : 1.1 (0.5) min < med < max: 1 < 1 < 5 IQR (CV) : 0 (0.4)	1 : 509 (91.5%) 2 : 38 (6.8%) 3 : 4 (0.7%) 4 : 2 (0.4%) 5 : 3 (0.5%)	IIIIIIIIIIIIIIIIIIII I	556 (100.0%) (0.0%)
111	I111 [haven_labelled, vctrs_vctr, double]	During the last therapy session, how much did I check my watch with them more often than I usually do with my other patients.	Mean (sd) : 1.2 (0.5) min < med < max: 1 < 1 < 5 IQR (CV) : 0 (0.4)	1 : 486 (87.4%) 2 : 54 (9.7%) 3 : 10 (1.8%) 4 : 5 (0.9%) 5 : 1 (0.2%)	IIIIIIIIIIIIIIIIIIII I	556 (100.0%) (0.0%)
112	I112 [haven_labelled, vctrs_vctr, double]	During the last therapy session, how much did I find it hard to step into their inner world.	Mean (sd) : 1.4 (0.7) min < med < max: 1 < 1 < 5 IQR (CV) : 1 (0.5)	1 : 358 (64.4%) 2 : 166 (29.9%) 3 : 25 (4.5%) 4 : 5 (0.9%) 5 : 2 (0.4%)	IIIIIIIIIIIIIIIIIIII IIIII	556 (100.0%) (0.0%)
113	I113 [haven_labelled, vctrs_vctr, double]	During the last therapy session, how much did I find it hard to emotionally understand their emotions, thoughts, and behaviors from their point of view.	Mean (sd) : 1.3 (0.6) min < med < max: 1 < 1 < 5 IQR (CV) : 1 (0.4)	1 : 413 (74.3%) 2 : 122 (21.9%) 3 : 18 (3.2%) 4 : 2 (0.4%) 5 : 1 (0.2%)	IIIIIIIIIIIIIIIIIIII IIIII	556 (100.0%) (0.0%)
114	I114 [haven_labelled, vctrs_vctr, double]	During the last therapy session, how much did I feel as if I was tied to my chair (e.g., rigid posture).	Mean (sd) : 1.1 (0.4) min < med < max: 1 < 1 < 4 IQR (CV) : 0 (0.4)	1 : 498 (89.6%) 2 : 48 (8.6%) 3 : 6 (1.1%) 4 : 4 (0.7%)	IIIIIIIIIIIIIIIIIIII I	556 (100.0%) (0.0%)
115	I115 [haven_labelled, vctrs_vctr, double]	During the last therapy session, how much did I feel like I could not verbally express something I thought was clinically useful.	Mean (sd) : 1.3 (0.6) min < med < max: 1 < 1 < 5 IQR (CV) : 0 (0.5)	1 : 439 (79.0%) 2 : 87 (15.6%) 3 : 21 (3.8%) 4 : 7 (1.3%) 5 : 2 (0.4%)	IIIIIIIIIIIIIIIIIIII III	556 (100.0%) (0.0%)
116	I116 [haven_labelled, vctrs_vctr, double]	During the last therapy session, how much did I have more difficulty than usual remembering the contents of their last session.	Mean (sd) : 1.2 (0.5) min < med < max: 1 < 1 < 4 IQR (CV) : 0 (0.4)	1 : 466 (83.8%) 2 : 77 (13.8%) 3 : 10 (1.8%) 4 : 3 (0.5%)	IIIIIIIIIIIIIIIIIIII II	556 (100.0%) (0.0%)

Supplementary Table 2. Fit indices confirming the unidimensionality of the three subscales from confirmatory factor analyses.

Scale	Items	χ^2	<i>df</i>	χ^2 / df	CFI	TLI	RMSEA	90% CI lower	90% CI upper	SRMR
Factor 1	<i>n</i> = 7	13.47	14	0.96	1.00	1.00	0.00	0.00	0.04	0.02
Factor 2	<i>n</i> = 7	46.24	14	3.30	0.96	0.94	0.06	0.04	0.09	0.04
Factor 3	<i>n</i> = 7	49.46	14	3.53	0.96	0.93	0.07	0.05	0.09	0.04

Note. CFI = Comparative Fit Index; *df* = degrees of freedom; RMSEA = Root Mean Squared Error of Approximation; SRMR = Standardized Root Mean Square Residual; TLI = Tucker-Lewis Index; χ^2 = Chi-square.

Supplementary Table 3. Descriptive statistics, internal consistency reliability, precision, and inter-scale correlations.

	Factor 1 Positively engaged	Factor 2 Enmeshed	Factor 3 Stuck
<i>Descriptive statistics</i>			
Potential Range	0 to 10	0 to 10	0 to 10
Observed Range	0 to 10	0 to 10	0 to 10
Mean, <i>SD</i>	9.07 (1.75)	2.37 (2.38)	1.74 (2.15)
POMP, <i>SD</i>	90.7 (17.5)	23.6 (23.8)	17.4 (21.5)
Skew	-2.66	1.08	1.59
Kurtosis	8.07	0.51	2.41
Standard Error of Measurement (<i>SE_e</i>)	0.84	1.14	1.03
Standard Error of Difference (<i>SE_d</i>)	1.19	1.61	1.46
<i>Internal consistency reliability</i>			
Average inter-item <i>r</i>	.41	.36	.39
Cronbach's alpha	.78	.74	.76
Mc Donald's omega total	.78	.75	.77

Note.

^a The 90% value is 1.65 times *the SE_e*. It provides a threshold to be 90% positive that within-patient change between two time-point observations is likely to reflect a “real” change rather than a measurement error.

^b The 95% value is 1.96 times the *SE_e*.

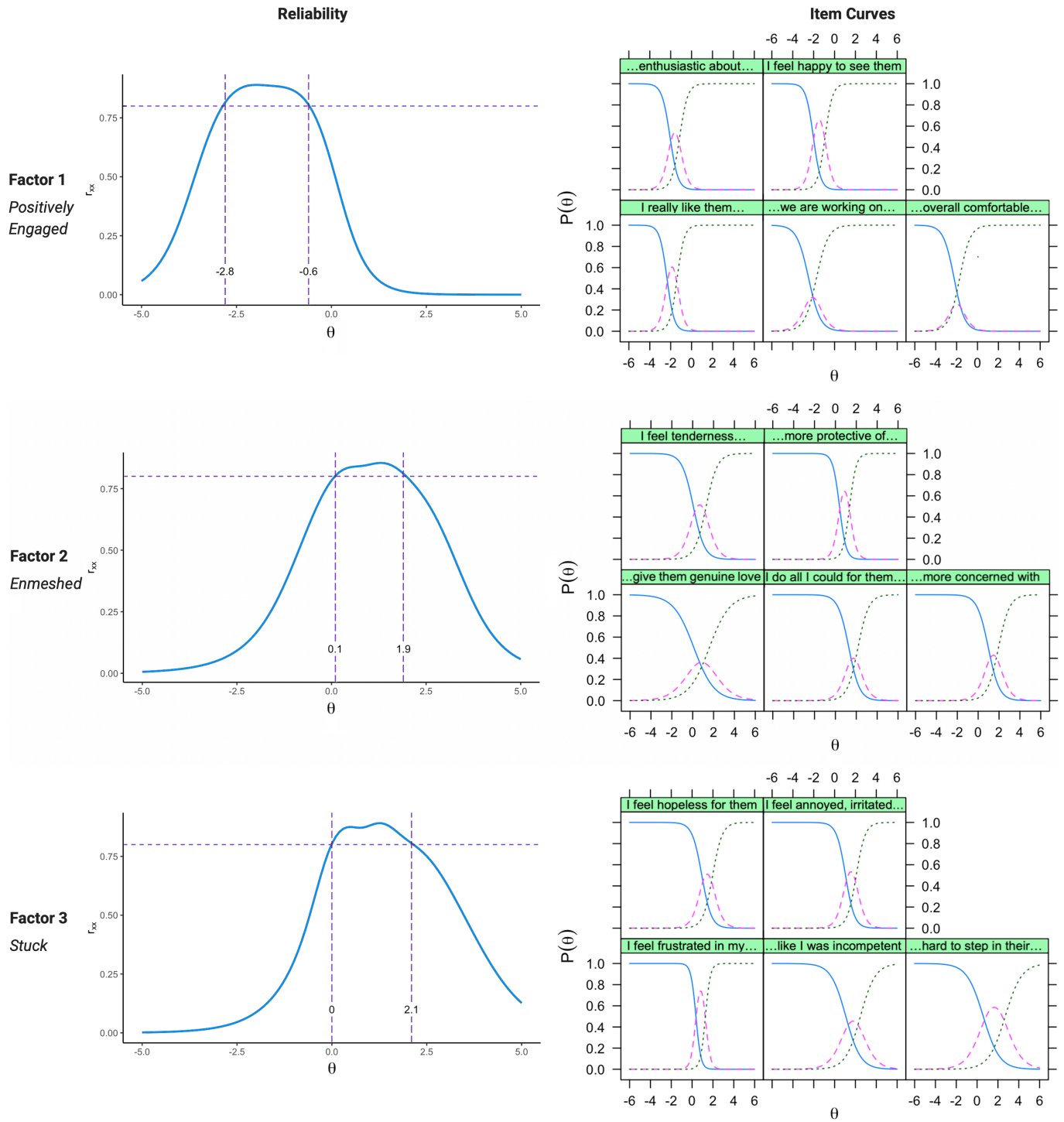

Supplementary Figure 1. Reliability and item characteristic curves for the scale scores.

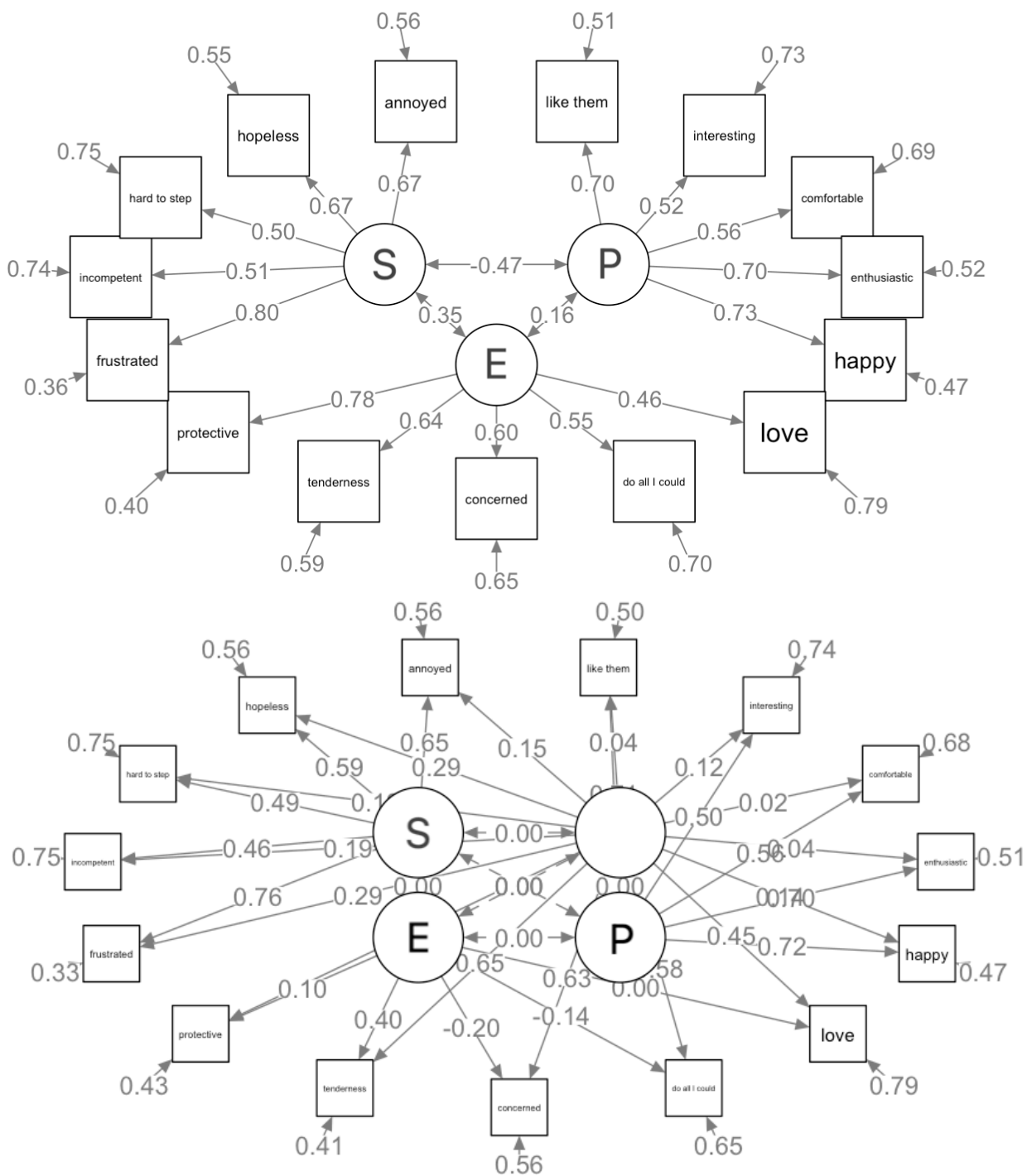

Supplementary Figure 2. Measurement models from confirmatory factor analysis (N = 556) presenting a fully standardized solution using robust maximum likelihood estimation.